

Signals

16" Pedestrian Signal Aluminum & Polycarbonate

Traffic signals and pedestrian signals represent the foundation of safety at any signalized intersection. They also represent the first, and arguably the most important, interaction motorists, bicyclists and pedestrians have with Intelligent Transportation Systems (ITS).

When it comes to ensuring that pedestrians are able to safely cross an intersection from different directions, Econolite provides transportation agencies with many options. Our 16" pedestrian signal housings are made from durable, corrosion-resistant aluminum and polycarbonate material.

We utilize the latest industrial design techniques to develop and manufacture the industry's most durable signal products that meet or exceed industry specifications.

Key Features

- Door can be mounted with the hinge on the top or bottom
- Two latch screws with wing nuts allow easy opening without the use of hand tools
- Signal assemblies provided with or without LED inserts installed
- ISO 9001: 2015-certified
- Tested to ITE required wind loading on single-point attachment



Tunnel Visor



Solar Screen



Terminal Mount



16" Pedestrian Housing



Durable Housing and Corrosion Resistant Finishes

Aluminum Housing/Door

The housing and door of each pedestrian signal is a one-piece corrosion-resistant aluminum alloy die-casting conforming to ASTM B85 Standard SG100B.

Painting of Aluminum Housing/Door/Visor:

- All interior and exterior surfaces are pre-treated for painting
- Degreased, rinsed, and etched with an iron phosphate solution
- Rinsed with a final deionized water rinse, then dried for 10 minutes at 400°F
- Painted with a single coat of environmentally safe, ultraviolet-resistant, polyester powder coating that is applied electrostatically at 90 kV and baked for 20 minutes at 400°F
- Meets ASTM D-3359, ASTM D-3363, and ASTM D-522

Polycarbonate Housing/Door

The housing and door of each pedestrian signal is a one-piece molded, ultraviolet, and heat-stabilized unit made from virgin polycarbonate resin.

Shurlock Boss

Radial angular grooves cast into the top and bottom of the pedestrian signal housing (along with Econolite Shurlock fittings) permit alignment adjustments in five-degree increments and hold the head firmly in place. They also permit any section to be rotated independently about the vertical axis and hold each section securely in place to prevent misalignment.

Terminal Block

A terminal block with "Fast-on" tabs on one side and screw clamps on the other side is provided in a standard signal assembly. Mounting points for a second block are also present. Raised letters cast into the housing identify each position on the terminal block.

Standard Specifications

Size	Dimensions / Weight per section
16" Aluminum	16.37 in. H x 17.94 in. W x 4.91 in. D
16" Polycarbonate	16.33 in. H x 17.89 in. W x 7.05 in. D
Weight	<ul style="list-style-type: none"> - 16" Polycarbonate: 70 lb - 16" Aluminum: 12.5 lb - Terminal Mount: 4.2 lb <i>*Includes housing, door, and screen</i>
Material	<ul style="list-style-type: none"> - Polycarbonate Housing Thickness 0.12" - Polycarbonate Door Thickness 0.13" - Aluminum Housing Thickness 0.095" - Aluminum Door Thickness 0.10"
Standard Color(s)	Dark Olive Green - Matches Federal Standard 595b-14056 Yellow - Matches Federal Standard 595b-13538 Flat Black - Matches Federal Standard 595b-37038 Gloss Black (Aluminum only) - Cardinal T009-BK12

Field Terminal Mounting Bracket

An optional field terminal mounting bracket is available for both the aluminum and polycarbonate signals. This bracket includes an aluminum base that mounts to the side of the signal housing and a hinged plate that mounts to the side of the signal pole. Pedestrian signals can be ordered with the bracket mounted on the right or left side of the housing, with the knockouts intact. The terminal block(s) can be specified to be mounted in the bracket, the housing or both.

Options

- Tunnel visor
- Solar screen
- Terminal compartment mounting – left or right
- LED holding clips – polycarbonate only
- Location, quantity, and type of terminal blocks
- Accepts all manufacturers' LED inserts

16" Pedestrian Signal Housing

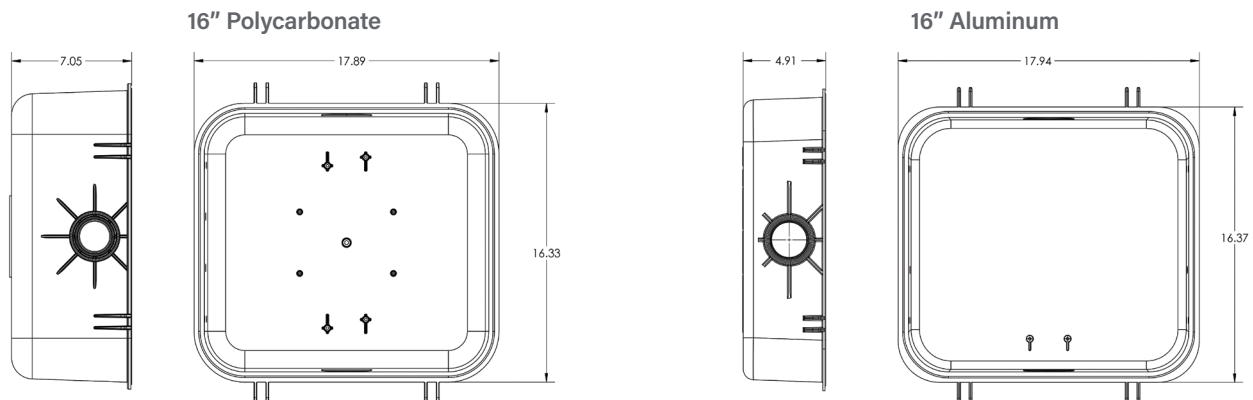

Dimensions and weights are approximate and may vary.