

Cabinets for Traffic Management

303B Cabinets

Traffic control cabinets house the brains and intelligence of the signalized intersection. Traffic cabinets also provide the standardized component communications, configuration, and safeguards that ensure safer and more efficient intersections.

Traffic cabinets are smarter, providing new options for communications, reduced and alternative power sources, and support big data and analytics that will help cities, municipalities, and DOTs meet the traffic management needs well into the future.

Through strict adherence to industry standards and specifications, and utilizing leading-edge component and communications technologies, Econolite's traffic control cabinets ensure the highest levels of intersection safety and traffic management capabilities.

Safetran
BY ECONOLITE

Key Features

- Single-door access
- Mountable on base, side of pole, side of traffic cabinet, or top of post
- Cam locking system (three-point locking optional)
- Suited for battery Uninterruptible Power Source (UPS) and accessories
- 0.125/0.188-inch thick aluminum

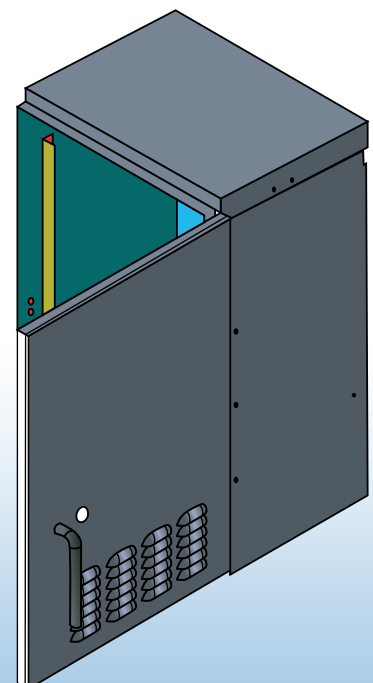



Description

The cabinet design houses a UPS unit and batteries for an uninterruptible power supply back-up at intersections. Constructed of heavy 0.125/0.188-inch aluminum, the 303B provides a durable, weatherproof enclosure. A middle shelf is optionally available, and a removable lower shelf is included. The 303B can be mounted on the side of the cabinet, side of the pole, top of the post, or on the base. The cabinet side-mounts with bolts to almost any traffic control cabinet and provides interfacing through a hole and sturdy nipple connection. The cabinet can be provided with a front-mounted fluorescent light. The 303B was designed for applications where a smaller, more compact cabinet is desired.

Basic Specifications

• Dimensions

- 36 in. H x 20 in. W x 17 in. D
(battery space - 20.25 in. x 13.30 in.)

• Material

- Aluminum
0.125 in. (door and top)
0.188 in. (sides and bottom)

• Ship Weight

- 95 lbs

• Finish

- Anodized, bare, painted, or anti-graffiti

